

06 Electronic Valves – The Mouse Valve Series



Clippard Functional Simplicity

- The design of Clippard electronic valves is a deceptively simple arrangement with a minimum of operating parts, and remarkably straight forward low power operation.
- The Clippard “spider” is the only moving part and its motion to operate the valve is a mere 0.18 mm travel.
- Low voltage D.C. inputs, signals from simple manual switching up to computer directed systems, move the spider in extremely fast response time ... 5 to 10 milliseconds.
- The unit uses extremely low power (0.67 watts at the rated voltage) and is cool running. The valves are light in weight, compact in physical size and mount easily in space-saving packages.



Quick Connect

Clippard ET valves feature spade lugs for simple, quick secure low voltage connections. Wire crimp-on spade lug connectors are available separately to adapt electronic wiring where necessary. Clippard original EV type valves are available in popular voltages with 450 mm wire leads. The EC model utilizes a 0.6 mm square pin connector.

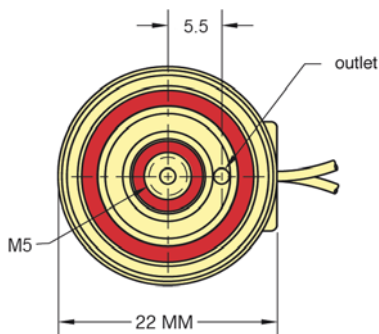

Easy Mounting

The complete line of EC, EV, ET and EW electronic valves are available with two mounting options. Standard base models have two M3 x 5.5 mounting holes. Manifold models are equipped with a bottom stud, with M5 x 4 thread, which fits Clippard standard and special manifolds, accessory valves and subplates. Spanner holes in the valve body permit tightening.

Series	Nominal			Power	Working range
	Voltage	Current (amps)	Resistance (ohms)	(watts)	(cont. duty)
Standard Oxygen Clean Analytical	12	0.055	218	0.67	90 to 150% of rated voltage
	24	0.028	864	0.67	
Corrosion- Resistant	12	0.098	122	1.2	90 to 110% of rated voltage
	24	0.049	486	1.2	
EM Series	12	0.083	144	1.0	90 to 120% of rated voltage
ES Series	24	0.042	576	1.0	